



3P Volumefilter VF2 – VF6
Rainwater Filters for installation within manhole chambers

3P Volumefilter VF2



Art.-Nr. 1000600

For roof areas up to 1150 m².
 Rainwater Inlet diameter at 200 mm.
 Outlet to storage tank at 150 mm.
 Sewer connection in the manhole at 200 mm diameter.
 Height difference between rainwater inlet and outlet to tank just 32 cm.
 Filter insert easily removed for cleaning.
 Maximum flow rate of 25.5 l/s.

3P Volumefilter VF3



Art.-Nr. 1000700

For roof areas up to 1500 m².
 2 No. Rainwater Inlets at diameter 200 mm.
 Outlet to storage tank at 150 mm.
 Sewer connection in the manhole at 200 mm diameter.
 Height difference between rainwater inlet and outlet to tank just 32 cm. Lamella unit with integral fine filter easily removed for cleaning.
 Maximum flow rate of 33 l/s.
 The 3P Volumefilter VF3 can be easily converted into the 3P Volumefilter VF4.

3P Volumenfilter VF4



Art.-Nr. 1000800

For roof areas up to 2300 m².
 2 No. Rainwater Inlets at diameter 250 mm.
 Outlet to storage tank at 150 mm.
 Sewer connection in the manhole at 250 mm diameter.
 Height difference between rainwater inlet and outlet to tank just 32 cm. Lamella unit with integral fine filter easily removed for cleaning.
 Maximum flow rate of 51.5 l/s.

3P Volumefilter VF6



Art.-Nr. 1000900

For roof areas up to 3200 m².
 2 No. Rainwater Inlets at diameter 250 mm.
 Outlet to storage tank at 200 mm.
 Sewer connection is to be provided in the manhole at a diameter of OD 250 mm.
 Height difference between rainwater inlet and outlet to tank just 32 cm.
 Lamella unit with integral fine filter easily removed for cleaning.
 Maximum flow rate of 70.5 l/s.

Installation
Installation-Instructions

Operating
Operating-Instruction

3P Volumefilter VF2 - VF6

Please read all the following information, which contains important instructions for the use and maintenance of the 3P Volumefilters VF2 - VF6.

Contents	Page
1. Technical data	_02
.....	_03
2. How it works	_04
3. Usage	_04
4. Installation guide	_05
4.1 Installation	_05
.....	_06
4.2 Installation advice	_07
4.3 Optimal installation situation.....	_07
5. Cleaning the filter	_08
5.1 Removal of lamella unit	_08
5.1 Maintenance advice	_08

1. Technical data

Rainwater Filters for installation within manhole chambers.

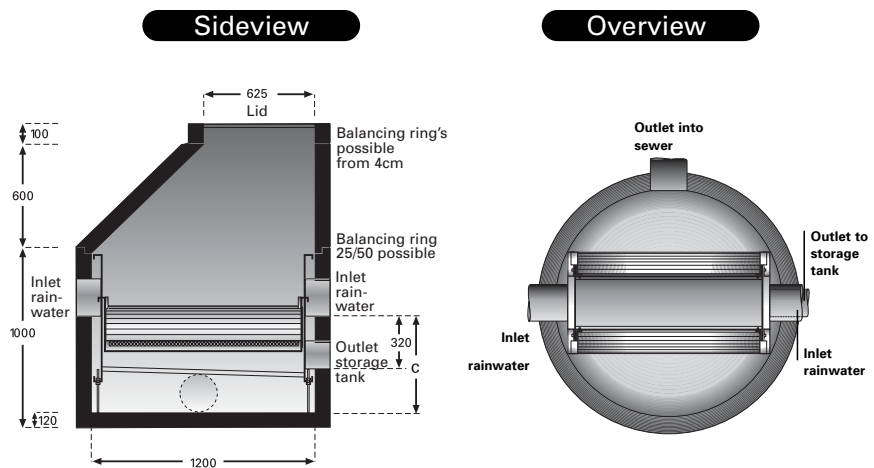

3P Volumefilter VF2 – VF6

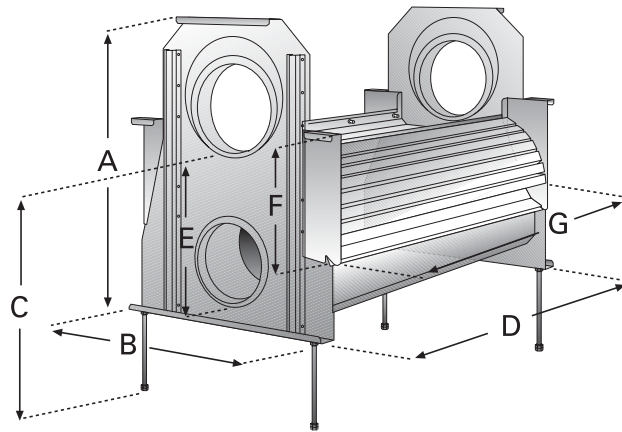

Filter	Inlet Rain-water	Outlet to sewer	Outlet to storage tank	A in mm	B in mm	C in mm	D in mm	E in mm	F in mm	G in mm	Mesh Size	min. Ø manhole	max. Water flow rate	Maximum Roof Area
VF2	1 x DN200	1 x DN200	1 x DN150	670	540	525	390	325	275	320	490 my	1000	25,5 l/sec	1150 m ²
VF3*	2 x ** DN200	1 x DN200	1 x DN150	670	540	525	980	325	275	880	490 my	1200	33,0 l/sec	1500 m ²
VF4	2 x ** DN250	1 x DN250	1 x DN150	670	540	575	980	325	275	880	490 my	1200	51,5 l/sec	2300 m ²
VF6	2 x ** DN250	1 x DN250	1 x DN200	670	540	575	980	325	275	880	490 my	1200	70,5 l/sec	3200 m ²

* VF3 has a filter unit only on one side .

** You don't need to use both inlets but filter capacity will be higher.

3P Volumefilter VF2 – VF6

2. How it works

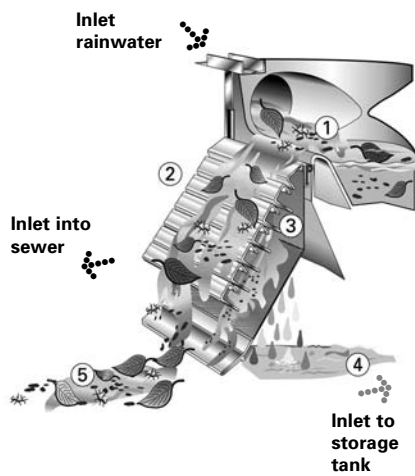

- ① As rain water arrives the water level builds up, and overtops the filter lip, so ensuring it is distributed evenly across the whole width of the filter cascade.
- ② Pre cleaning through the cascades. Larger dirt particles are washed across the cascades directly to the sewer.
- ③ Pre filtered water then flows over the secondary filter (mesh size 0.55 mm). Due to the special structure of the sieve mesh, any dirt is washed directly into the sewer which means the filter is self cleaning, low maintenance.
- ④ Cleaned water flows to the storage tank.
- ⑤ Dirt goes to the sewer.

3. Usage

Rainwater Filters for larger roof areas.

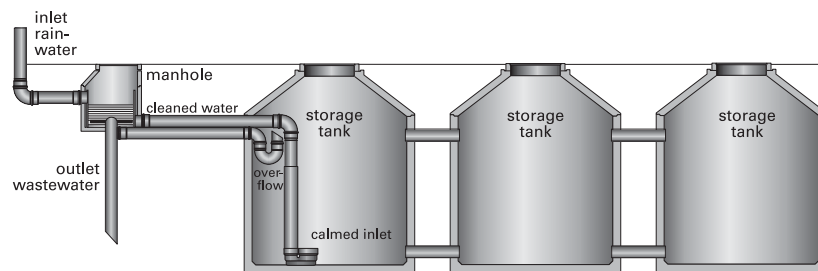

4. Installation guide

4.1. Installation

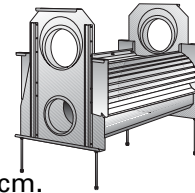

Manhole: Chamber diameter 100 or 120 cm.

We recommend installing the filter in its working position. From experience in the "real world" we recommend use of short connection pipe lengths to any manhole chamber, pushed in from the outside through the chamber wall inlets into the corresponding connections of the filter.

This will help to minimise the risk of the connecting pipes or the seals being displaced during the subsequent construction process. (settlement etc.)

When connected directly at the building site please make sure that all seals are set correctly.

The pipes should not project into the filter more than 5 cm.

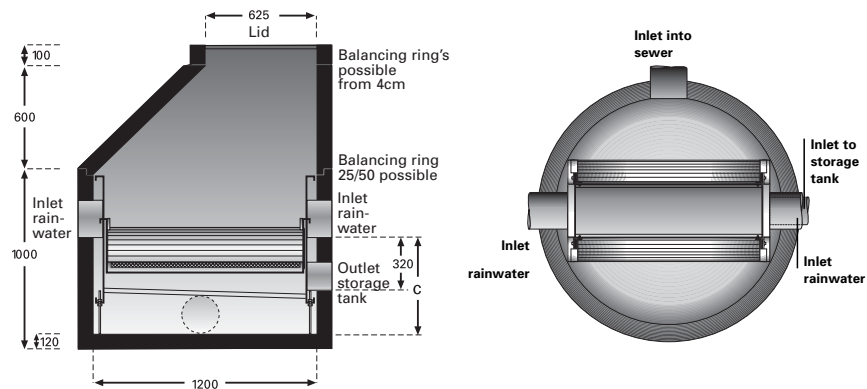

The filter should be installed perpendicular and horizontal. There are adjustable feet to accommodate small height differences. The manhole itself should be set level. The manhole chamber base should ideally have a gradient of approximately 5% or more towards the sewer outlet. This ensures any sediment is more easily rinsed away.

We strongly recommend that the distance between the manhole floor and the lower sump in the filter should be at least as big as the filter inlet diameter.

You can adjust this distance with the help of the adjustable feet (the threaded bars). You may wish to have your installer/drainage contractor prepare the manhole chamber according to the following conditions. The diameter of the chamber wall orifices will depend on the selected seals for the pipes.

Outlet to waste:

Base of outlet pipe = base of manhole

Inlet to storage tank:

Base of the inlet pipe = x cm
above floor of manhole chamber
(see Table at page 3 for data, C-E)

2 x inlets rainwater:

Invert of 2 No inlet pipes = 32 cm from invert of pipe outlet to storage tank, which is therefore 57 cm from base (floor) of chamber.
(Dimension "C" on page 3)

3P Volumefilter VF2 – VF6

4.2. Installation advice

We recommend you remove the filter mesh unit(s) before installation.

Install the 4 threaded bolt feet, length c. 25 cm, and lower the filter into the manhole.

Now push the connection pipe (and seals) through the manhole wall into the corresponding sealing rings of the filter. Small height differences are then further adjustable using the adjustable feet (threaded bolts).

Check, with a spirit level, that water will be level in the filter's receiving sump for optimal performance.

Replace the lamella filter mesh unit(s) once construction is complete.

We also recommend covering the filter during installation to keep it clean (during any setting of concrete rings and lid etc.)

4.3. Optimal installation situation

By pass and inlet feed to both sides of filter.

High security due to bypass installation, because of this you can connect to larger roof areas.

Higher efficiency through inlet feed from both sides of filter.

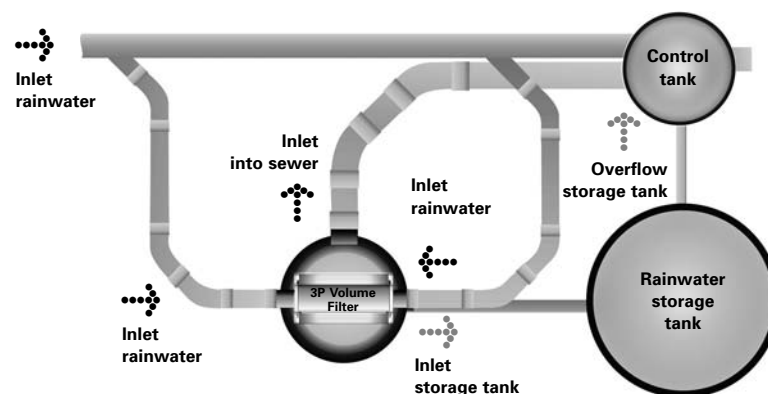



5. Cleaning the filter

Monitor the filter regularly, clean if necessary.

5.1. Removal of lamella unit

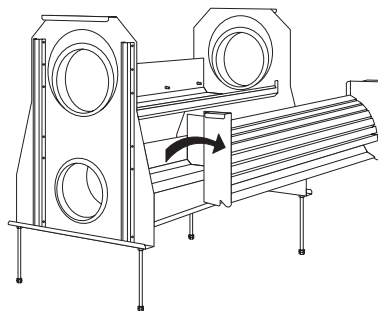

5.2. Maintenance advice

1. Once a year flush out the sump and manhole with a hose.
The sump can be emptied through a little orifice in the sump floor.
Therefore the inlet to the tank should be sealed temporarily.
2. The lamella unit can be cleaned with a high pressure cleaner,
but take care not to hold any lance too close to the delicate mesh,
lest it damage the mesh itself.

Regenwasser@3PTechnik.de

www.3PTechnik.com